

INSTALLATION, SERVICE & PARTS MANUAL

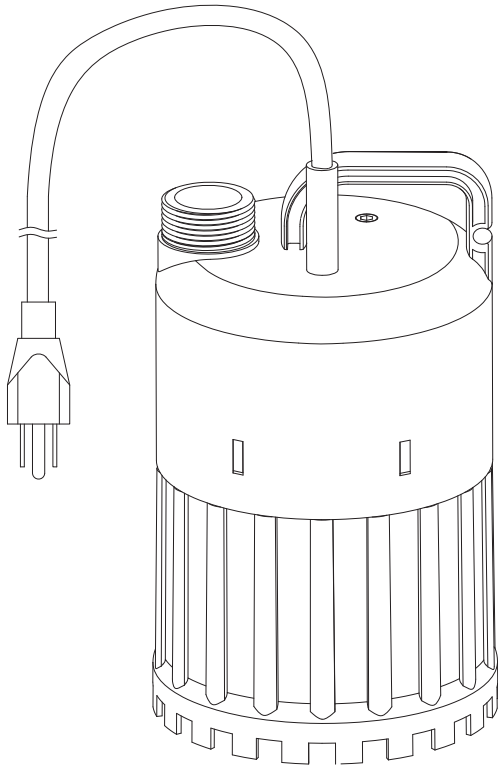

Series: PFUT06

**1/6 HP
3450 RPM • 60 Hz
Portable Utility / Sump Pumps**



Power-Flo Pumps & Systems

a Power-Flo Technologies company

General Safety Information

Before installation, read the following instructions carefully. Failure to follow instruction and Safety information could cause serious bodily injury, death and/or property damage. Each Power-Flo pump is individually factory tested to insure proper performance. Closely following these instructions will eliminate potential operating problems, assuring years of trouble-free service.

⚠ WARNING

- Risk of electric shock. To reduce risk of electric shock, always disconnect pump from power source before handling. Lock out power & tag.
- Installation must be in accordance with the National Electric Code and all applicable state and local codes.



ALL RETURNED PRODUCTS MUST BE CLEANED, SANITIZED, OR RECONTAMINATED PRIOR TO SHIPMENT,

TO INSURE EMPLOYEES WILL NOT BE EXPOSED TO HEALTH HAZARDS IN HANDLING SAID MATERIAL. ALL APPLICABLE LAWS AND REGULATIONS SHALL APPLY.

IMPORTANT!

Prior to installation, record Model Number, MFG Date, and/or serial number, from pump name plate for future reference.

Model:
Serial:
MFG Date:

⚠ WARNING

- Installation and servicing is to be conducted by qualified personnel.
- These pumps are NOT to be installed in locations classified as hazardous in accordance with the National Electric Code, ANSI/NFPA 70.
- Keep clear of suction and discharge openings. Do not insert fingers in pump with power connected.
- Always wear eye protection when working on pumps.
- **DO NOT** use power cord to lift pump. Protect cable from cuts and punctures. Do not handle power cable with wet hands.
- **DO NOT** use these pumps in water over 77°F.
- Pumps build up heat and pressure during operation-allow time for pumps to cool before handling or servicing.



This pump is **NOT** intended for use in swimming pools or any body of water with human contact. Pumps when used as a decorative water fountain pump **MUST** be used in circuit protected by a Ground Fault Interrupter. Installations in Decorative Fountains or Water Features provided for visual enjoyment **MUST** be installed per ALL State and Local codes.



RISK OF ELECTRIC SHOCK, DEATH OR PERSONAL INJURY. If basement floor has water or moisture on it, do not walk on this area until ALL power has been turned OFF. If main breaker is in this area, call electric authority to shut-off service, or call local fire department for assistance or instructions before attempting to service pump.



WARNING: CANCER AND REPRODUCTIVE HARM-
WWW.P65WARNINGS.CA.GOV

© Power-Flo is a registered trademark of Power-Flo Technologies Inc. Other brand and product names are trademarks or registered trademarks of their respective holders. Alteration Rights Reserved. 4/08, 1/09, 2/09, 6/09, 4/10, 1/2021

Specifications

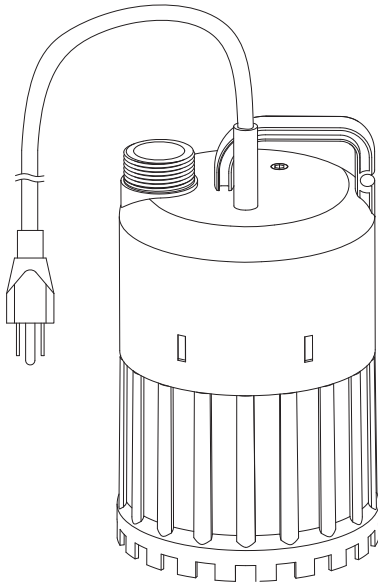

Series: PFUT06

**1/6HP, 3450 RPM, 60 Hz
Portable Utility Pumps**

DISCHARGE	1¼" NPT Male, Vertical
LIQUID TEMPERATURE	77°F Continuous
MOTOR HOUSING	Thermoplastic
PUMP STRAINER	Thermoplastic
IMPELLER	4 vane, semi-open Material: Thermoplastic
SHAFT	Steel
O-RINGS	Buna-N
HARDWARE	Stainless Steel
SEAL	Single Mechanical, Type 6 Material: Carbon/Ceramic/Buna-N
UPPER BEARING	Single, Row, Ball, Oil Lubricated
LOWER BEARING	Single, Row, Ball, Oil Lubricated
POWER CORD	15 Ft., cord with plug
MOTOR	Air Filled, Class B insulation
SINGLE PHASE	Permanent Split Capacitor (PSC). Includes Thermal Overload Protection in Motor

IMPORTANT! - For use in pumping water only!



Dimensions

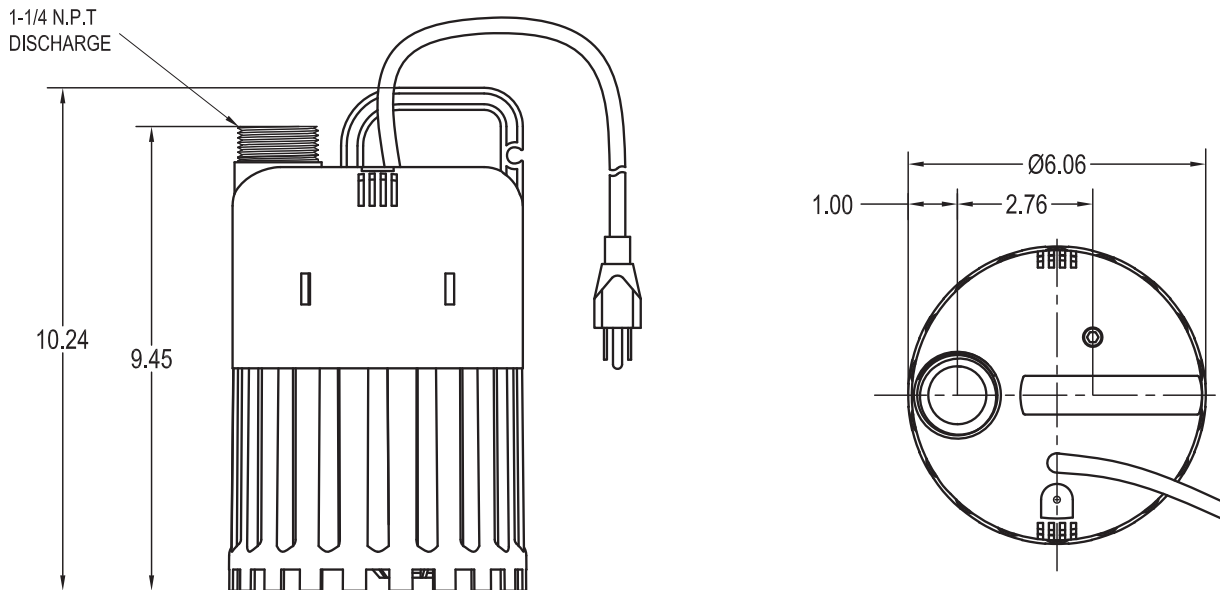

MODEL	HP	Hz	Volts/Ph	RPM	Full Load Amps	Cord Length	Cord Type
PFUT06	1/6	60	115/1	3450	2.0	15 Ft.	SJTW
Locked Rotor Amps		NEMA Start Code		Winding Resistance, MAIN-START			
8.8		G		11 -- 18.5			



Performance

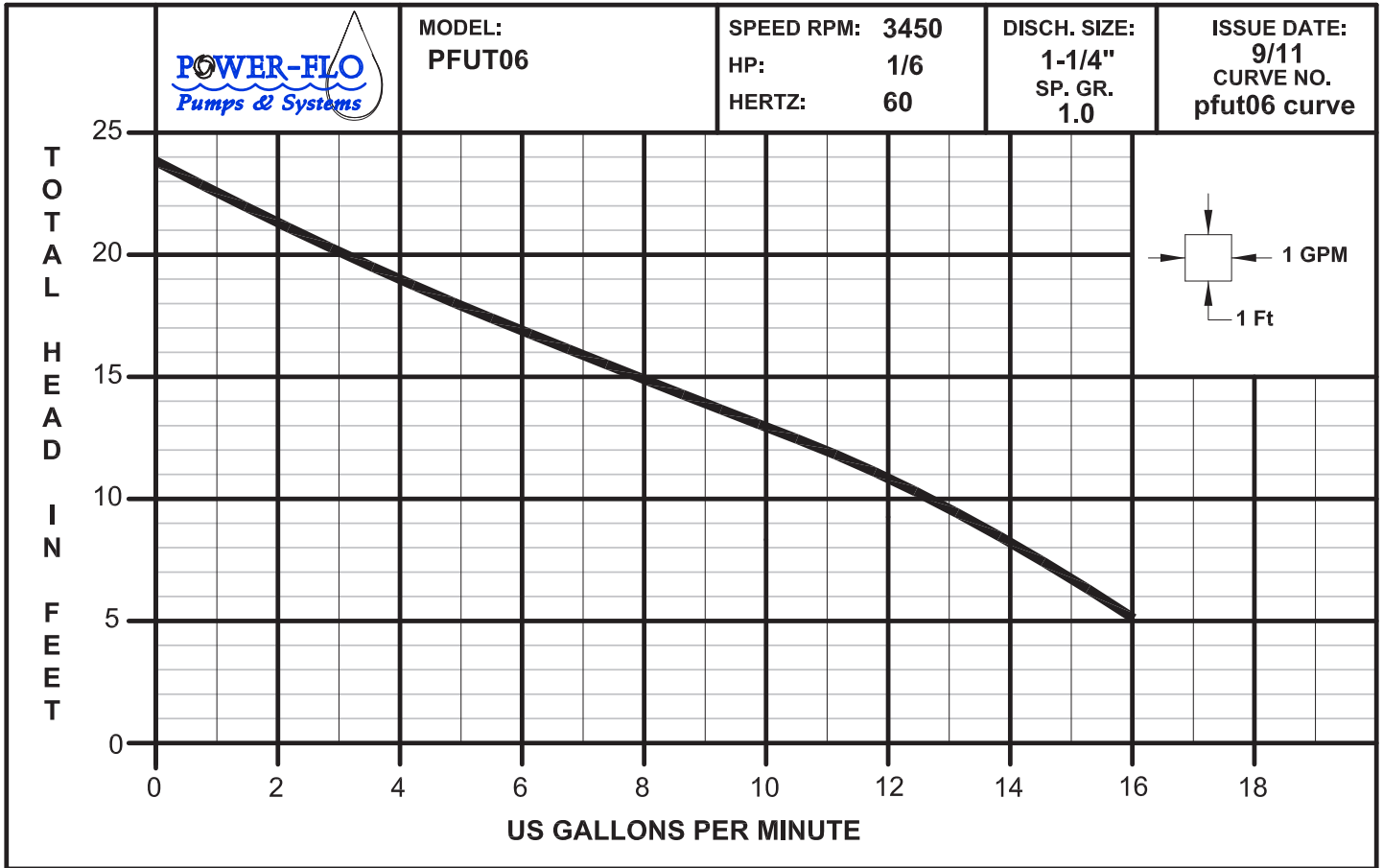

Installation

Receiving Inspection

Upon receiving the pump, it should be inspected for damage or shortages. If damage has occurred, file a claim immediately with the company that delivered the pump. If the manual is removed from the packaging, do not lose or misplace.

Storage

Any product that is stored for a period longer than six (6) months from the date of purchase should be bench tested prior to installation. A bench test consists of, checking the impeller to assure it is free turning and a run test to assure the motor (and switch if provided) operate properly. Do not pump out of liquid.

Controls

Manual models require a separate approved pump control device or panel for automatic operation. Be sure the electrical specification of the control selected properly match the electrical specifications of the pump.

It is recommended that a sump pump system have an audio and visual alarm that signals a malfunction of the system to reduce the potential for property damage.

Submergence

The pump should always be operated in the submerged condition. The minimum sump liquid level should never be less than above the pump.

Liquid Level Controls

Typical Discharge Pipe Mounted:

Refer to Figure 1 which shows a typical installation of a 1 phase 115 volt pump using a level control mounted to the discharge piping with a piggy-back plug. The level control should have adequate clearance so it cannot hang up in it's swing and that the pump is completely submerged when the level control is in the "Off" mode. By adjusting the cord tether the control level can be changed.

Typical Installation with Wide Angle Level Control

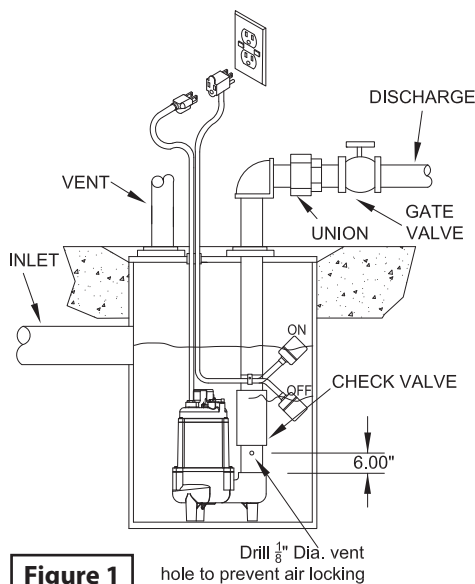

Figure 1

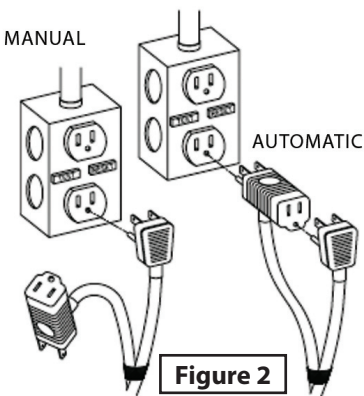

Figure 2

- Automatic:** Plug float cord into GFI outlet, then plug pump cord into float cord.
- Manual:** Plug pump cord directly into GFI outlet.

Level Control Basic Instructions:

Plug the level control plug into the GFI receptacle, then plug the pump into the piggy-back plug (See Figure 2). One cycle of operation should be observed, so that any potential problems can be corrected.

It is recommended that the level control float should be set to insure that the liquid in the sump never drops below the top of the motor housing.

Installation

These pumps are recommended for use in a sump or basin. The sump or basin shall be sealed and vented in accordance with local plumbing codes.

This pump is designed to pump water, nonexplosive and noncorrosive liquids and shall NOT be installed in locations classified as hazardous in accordance with the National Electrical Code (NEC) ANSI/NFPA 70 or Canadian Electric Code (CEC).

The minimum sump depth should be at least 24". Check the dimensions for minimum sump diameter. These are minimum requirements.

The pump should never be installed in a trench, ditch, or hole with a dirt bottom. The legs will sink into the dirt and the suction will become plugged.

Discharge Piping

Discharge piping should be as short as possible and sized no smaller than the pump discharge. **Do not reduce the discharge pipe size below that which is provided on the pump.** Both a check valve and a shut-off valve are recommended for each pump.

The check valve is used to prevent backflow into the sump. The shut-off valve is used to manually stop system flow during pump servicing.

Electrical Connections

The power cable mounted to the pump must not be modified in any way. This pump is provided with a 3 wire cord and 3 prong grounded plug that must be connected into a 3 wire grounded Ground Fault receptacle. **DO NOT USE THE POWER CABLE TO LIFT PUMP. Do not use an extension cord.**



Installation

Always rely upon a Certified Electrician for installation.

Overload Protection:

Single Phase - The stator in-winding overload protector used is referred to as an inherent overheating protector and operates on the combined effect of temperature and current. This means that the overload protector will trip out and shut the pump off if the windings become too hot, or the load current passing through them becomes too high.

IMPORTANT! - The overload will then automatically reset and start the pump up after the motor cools to a safe temperature. In the event of an overload, the source of this condition should be determined and corrected immediately.

Pre-Operation

1. **Check Voltage and Phase**
Compare the voltage and phase information stamped on the pump name plate.
2. **Check Pump Rotation** - Improper motor rotation can result in poor pump performance and can damage the motor and/or pump. Incorrect rotation for Single-Phase pumps is unlikely. If the rotation is incorrect contact factory.
3. **Name Plate** - Record the information from the pump name plate to drawing in front of manual for future reference.
4. **Insulation Test** - An insulation (megger) test should be performed on the motor. Before the pump is put into service.

The resistance values (ohms) as well as the voltage (volts) and current (amps) should be recorded.

5. **Pump-Down Test** - Be sure pump has been properly wired, lowered into the basin, sump or lift station, check the system by filling with liquid and allowing the pump to operate through its pumping cycle. The time needed to empty the system, or pump-down time along with the volume of water, should be recorded.

Replacement Parts are not available for this unit.



Risk of electric shock. Always disconnect the pump from the power source before handling inspections or repairs.

Symptom	Possible Cause(s)	Corrective Action
Pump will not run or pump fluid	<ol style="list-style-type: none"> 1. Poor electrical connection, blown fuse, tripped breaker or other interruption of power; improper power supply 2. Defective motor 3. Insufficient liquid level 13. Debris plugging screen and suction intake 	<ol style="list-style-type: none"> 1. Check all electrical connections for security. Have electrician measure current in motor leads, if current is within $\pm 20\%$ of locked rotor Amps, impeller is probably locked. If current is 0, overload may be tripped. Remove power, allow pump to cool, then re-check current. 2. Replace pump. 3. Make sure liquid level is above the pump 4. Re-check all sizing calculations to determine proper pump size. 5. Check discharge line for restrictions, including ice if line passes through or into cold areas. 6. Remove and examine check valve for proper installation and freedom of operation 7. Open valve 8. Check impeller for freedom of operation, security and condition. Clean impeller cavity and inlet of any obstruction 9. Loosen union slightly to allow trapped air to escape. 10. Repair fixtures as required to eliminate leakage 11. Check pump temperature limits and fluid temperature 12. Replace portion of discharge pipe with flexible connector or tighten existing piping. 13. Check screen and/or suction inlet.
Pump hums but doesn't run	<ol style="list-style-type: none"> 1. Incorrect low voltage 8. Impeller jammed or loose on shaft, or inlet plugged 	
Pump delivers insufficient capacity	<ol style="list-style-type: none"> 1. Incorrect low voltage 4. Excessive inflow or pump not properly sized for application 5. Discharge restricted 6. Check valve partially closed or installed backwards 7. Shut-off valve closed 8. Impeller jammed or loose on shaft, or inlet plugged 9. Pump may be air locked causing pump not to flow 10. Piping fixtures leaking or discharge before the nozzle 13. Suction restricted 	
Pump shuts off and turns on independent of switch, (trips thermal overload protector). CAUTION! Pump may start unexpectedly. Disconnect power supply.	<ol style="list-style-type: none"> 1. Incorrect low voltage 4. Excessive inflow or pump not properly sized for application 8. Impeller jammed or loose on shaft, or inlet plugged 11. Excessive water temperature 	
Pump operates noisily or vibrates excessively	<ol style="list-style-type: none"> 2. Worn bearings, motor shaft bent 8. Debris in impeller cavity or broken impeller 12. Piping attachments to building structure too loose or rigid 	

NOTE: Power-Flo Pumps & Systems assumes no responsibility for damage or injury due to disassembly in the field. Disassembly of the pumps or supplied accessories other than at Power-Flo Pumps & Systems or its authorized service centers, automatically voids warranty.



LIMITED WARRANTY

Manufacturer warrants, to the immediate purchaser and subsequent initial owner during the warranty period, every new pump to be free from defects in material and workmanship under normal use and service, when properly used and maintained, for a period of eighteen (18) months from date of manufacture or twelve (12) months from date of installation (which ever comes first). Failure due to wear due to excessive abrasives is not covered. The initial owner is the purchaser who first uses the pump after its initial installation, or for non-permanent installation, the first owner who uses the pump. The date of installation shall be determined by a dated sales receipt noting the model and serial number of the pump. The dated sales receipt must accompany the returned pump. Product will be repaired, replaced or remanufactured at Manufacturer's option. No allowance will be made for shipping charges, damages, labor or other charges that may occur due to product failure, repair or replacement. This warranty does not apply to and there shall be no warranty for any material or product that has been disassembled without prior approval of Manufacturer, subjected to misuse, misapplication, neglect, alteration, accident or act of God; that has not been installed, operated or maintained in accordance with Manufacturer's installation instructions; that has been exposed to outside substances including but not limited to the following: sand, gravel, cement, mud, tar, hydrocarbons, hydrocarbon derivatives (oil, gasoline, solvents, etc.), or other abrasive or corrosive substances, wash towels or feminine sanitary products, etc. in all pumping applications. The warranty set out in the paragraph above is in lieu of all other warranties expressed or implied; and we do not authorize any representative or other person to assume for us any other liability in connection with our products. Contact Manufacturer at: 1-877-24PUMPS or www.powerflo pumps.com, Attention: Customer Service Department, to obtain any needed repair or replacement of part(s) or additional information pertaining to our warranty.

MANUFACTURER EXPRESSLY DISCLAIMS LIABILITY FOR SPECIAL, CONSEQUENTIAL OR INCIDENTAL DAMAGES OR BREACH OF EXPRESSED OR IMPLIED WARRANTY; AND ANY IMPLIED WARRANTY OF FITNESS FOR A PARTICULAR PURPOSE AND OF MERCHANTABILITY SHALL BE LIMITED TO THE DURATION OF THE EXPRESSED WARRANTY.

Some states do not allow limitations on the duration of an implied warranty, so the above limitation may not apply to you. Some states do not allow the exclusion or limitation of incidental or consequential damages, so the above limitation or exclusion may not apply to you. This warranty gives you specific legal rights and you may also have other rights which vary from state to state.

