



PFHM



1.3/3/4 HP • 3600 RPM • 60 HZ
BOOSTER PUMP



Features:

Close coupled stainless steel horizontal multistage pumps for municipal, commercial & industrial applications. Optimized for pressure boosting in water systems utilizing variable frequency drives.

- **Suction & DISCHARGE:** PFHM613 1”NPT, PFHM330/340 1-1/2”NPT
- **LIQUID TEMPERATURE:** 158°F (70°C)
- **Pump:** 304 Stainless Steel
- **IMPELLERS:** 304 Stainless Steel Dynamically Balanced
- **Close Coupled** with cast iron base
- **SEAL:** Cartridge type, Single mechanical, Carbon/Ceramic/Buna-N
- **BEARING:** Single row, ball
- **MOTOR:** Class F Insulation, TEFC, Premium efficient. Three phase motors are inverter duty
- **Simplex, Duplex & Triplex options**
- **Single Pump Flows from 5GPM to 60 GPM**
- **Heads to 250’ (108PSI of boost)**
- **Municipal booster service from 1 to 50 homes**
- **Commercial booster service to 750 Fixture Units**
- **WARRANTY:** 1 year



Horizontal Multistage Booster Pump

WARNING: CANCER AND REPRODUCTIVE HARM
WWW.P65WARNINGS.CA.GOV

Model	HP	Hz	Volts/Ph	RPM	Amps	Stages	Suction	Discharge	Weight
PFHM613-1	1.3	60	115-230/1	3600	12.7/6.4	6	1”NPT	1”NPT	24.3 lbs
PFHM330-1	3	60	230/1	3600	14	3	1 1/2”NPT	1 1/2”NPT	53 lbs
PFHM330-3	3	60	230-460/3	3600	8.3/4.5	3	1 1/2”NPT	1 1/2”NPT	53 lbs
PFHM340-3	4	60	230-460/3	3600	11.7/5.5	3	1-1/2”NPT	1-1/2”NPT	62 lbs

Not sure about which pump to choose or where to start? Simply scan our QR code to unlock our comprehensive manual, designed to guide you through the process of finding the perfect pump for your specific needs. Contact Power-Flo Pumps today.



PFHM613-1

1" Discharge

• 6 Stages

• 3600RPM

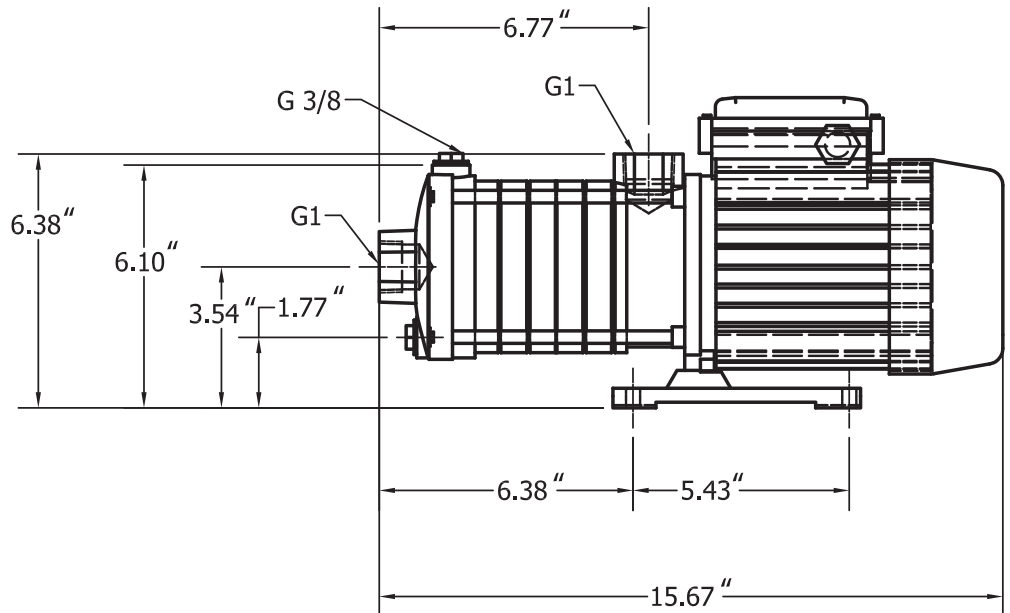
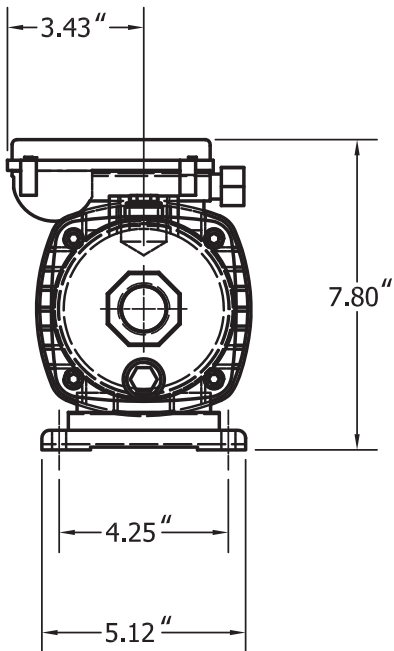



PFHM613-1

1" Discharge

• 6 Stages

• 3600RPM

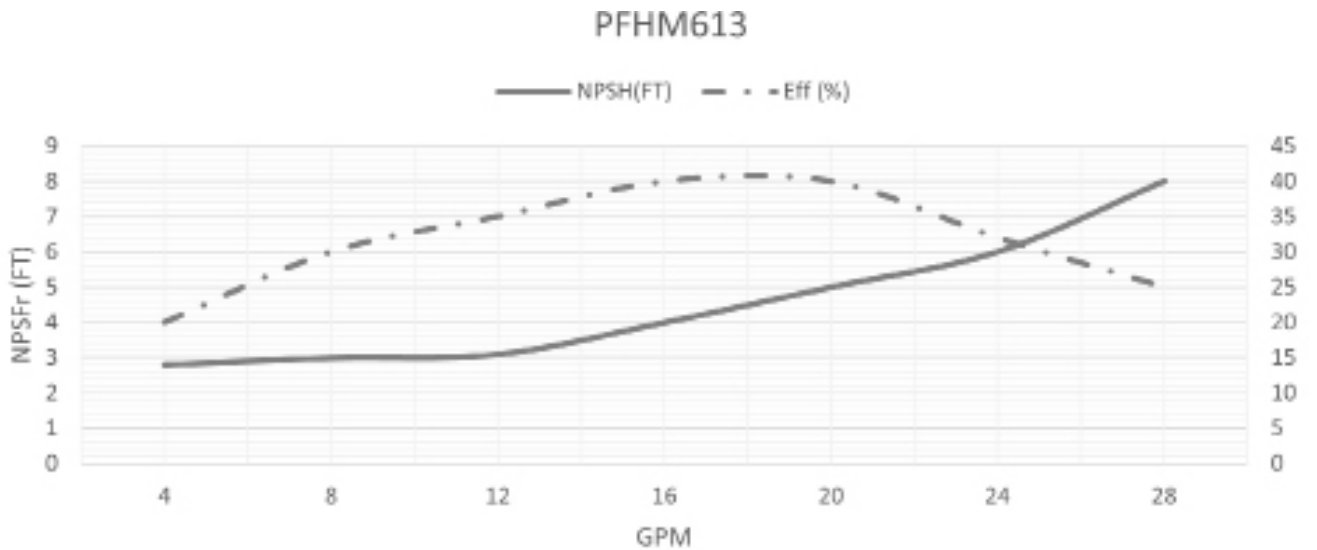
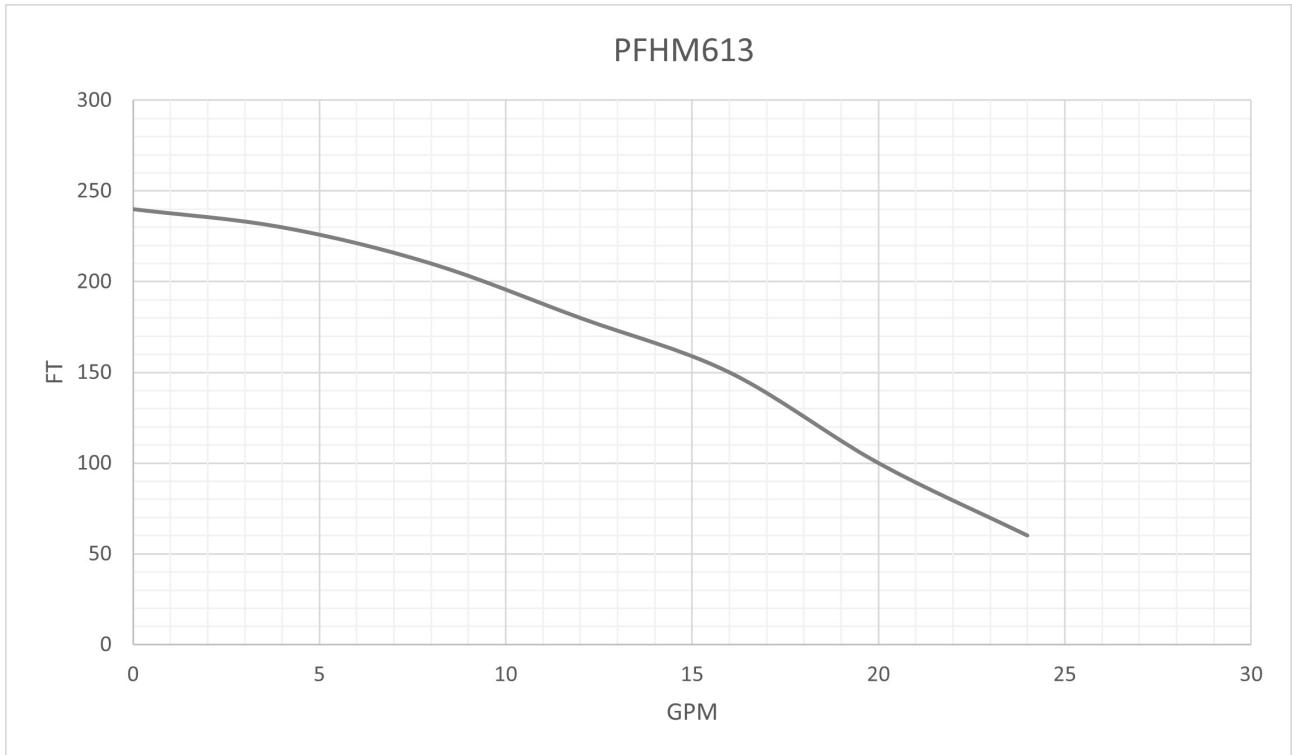

PFHM330-1 & PFHM330-3

1-1/2" Discharge



3 Stages



3600RPM

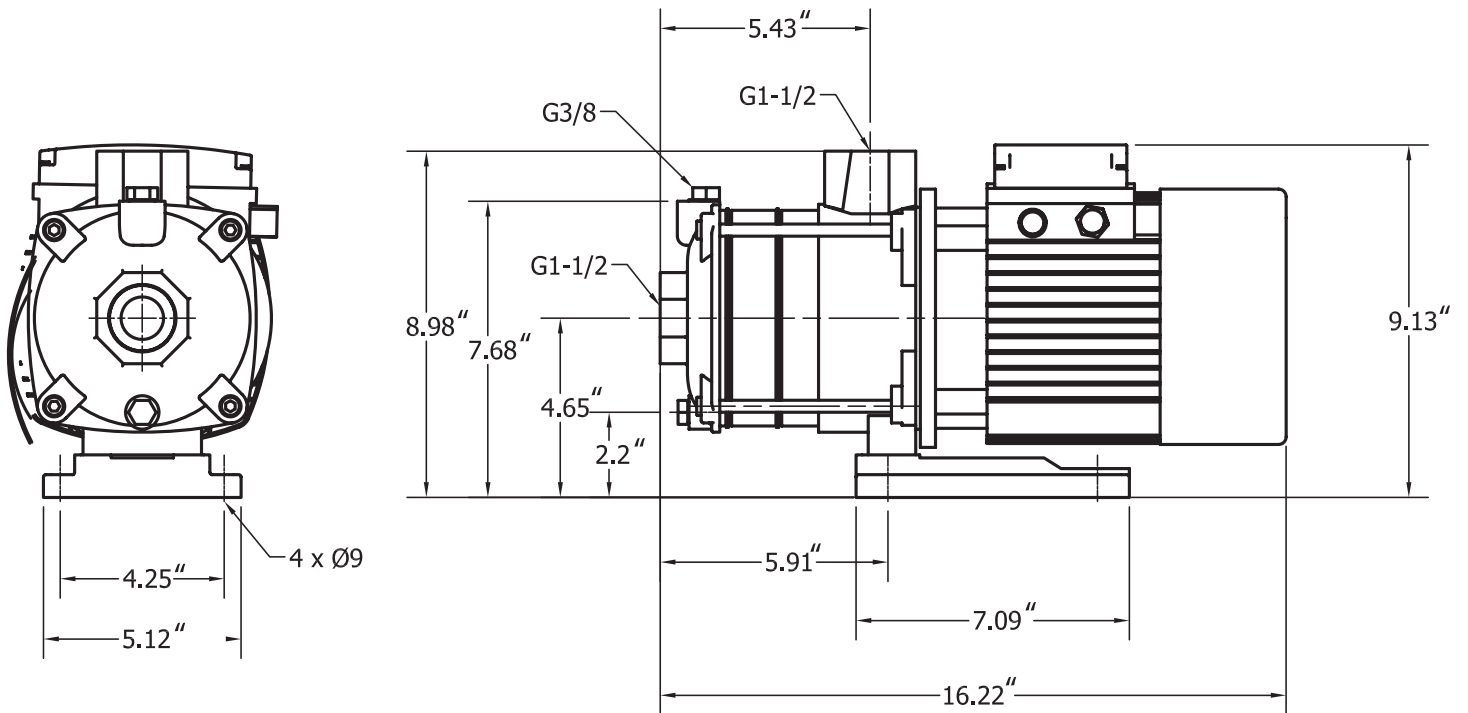



PFHM330-1 & PFHM330-3

1-1/2" Discharge



3 Stages



3600RPM

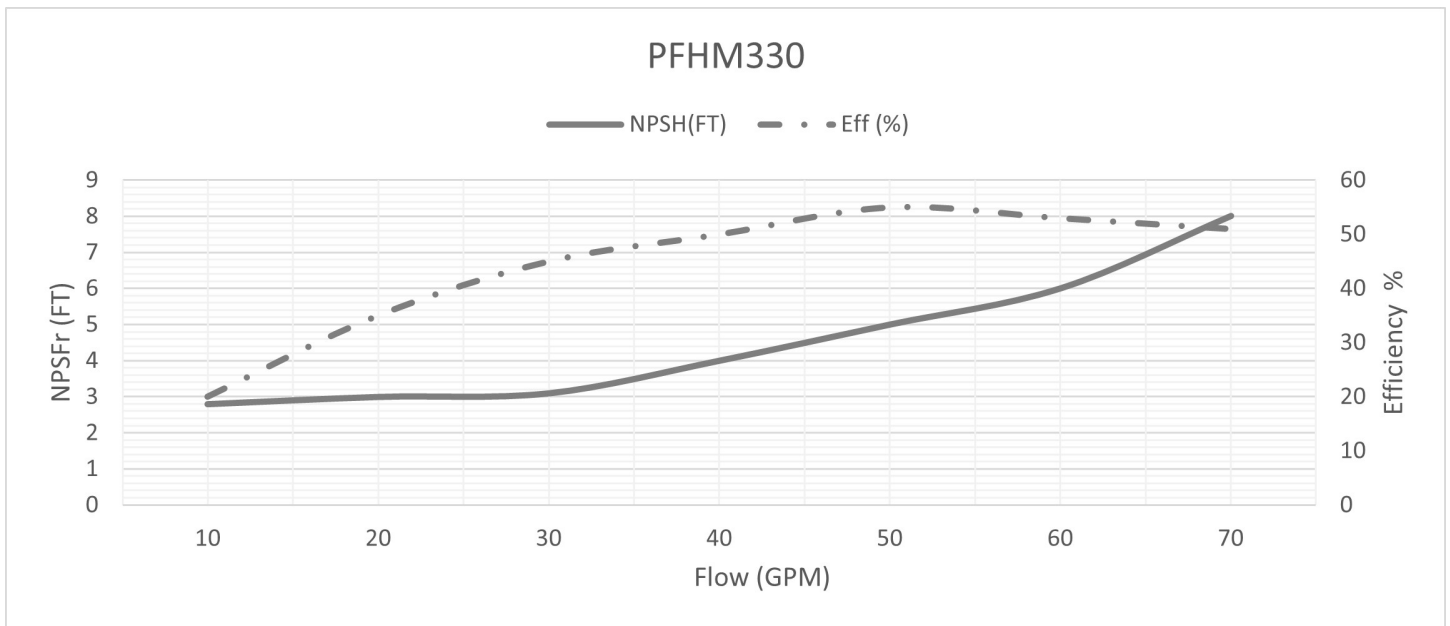
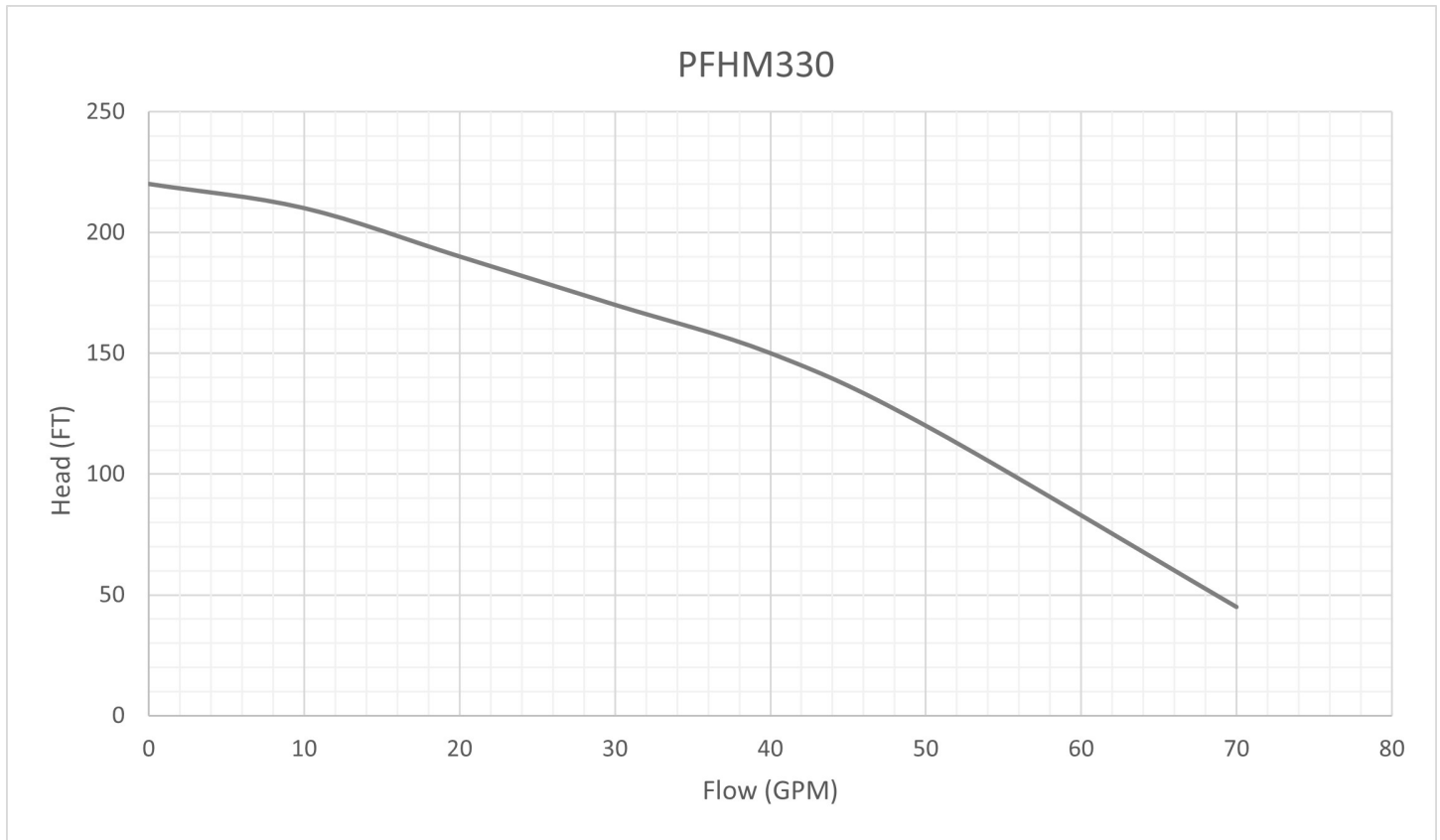

PFHM340-3

1-1/2" Discharge

• 3 Stages

• 3600RPM

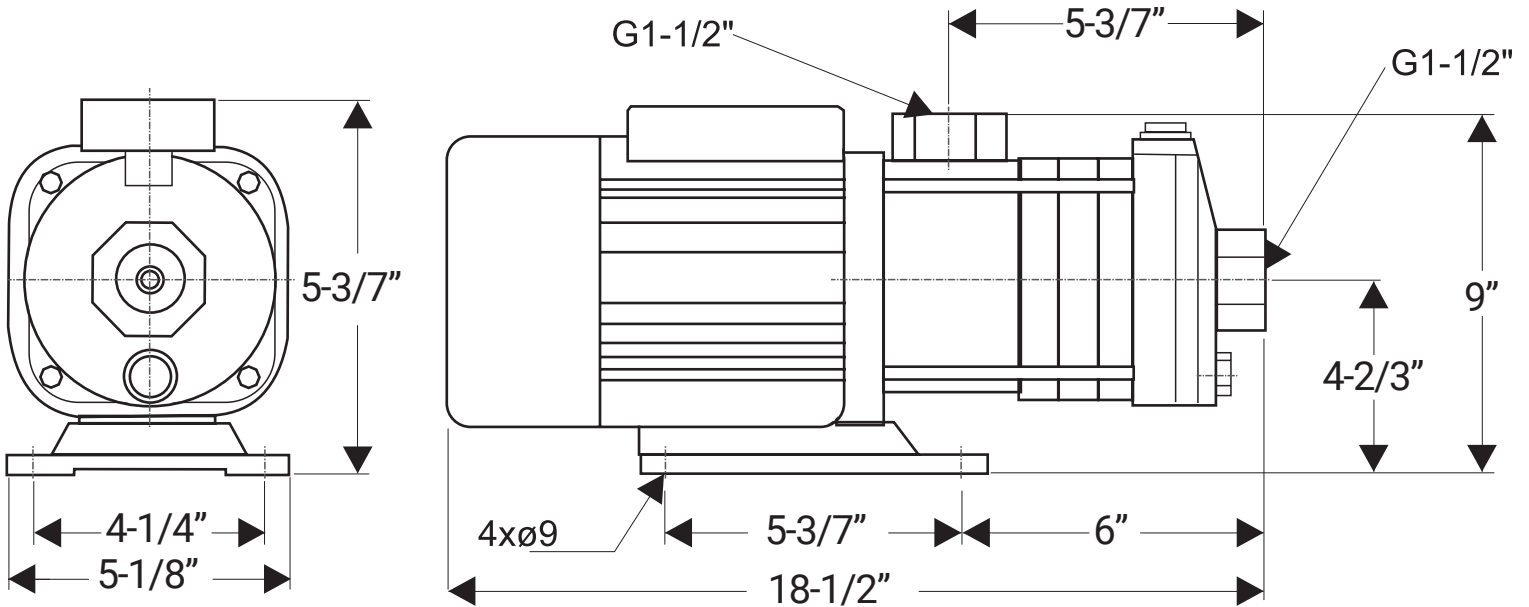



PFHM340-3

1-1/2" Discharge



3 Stages



3600RPM

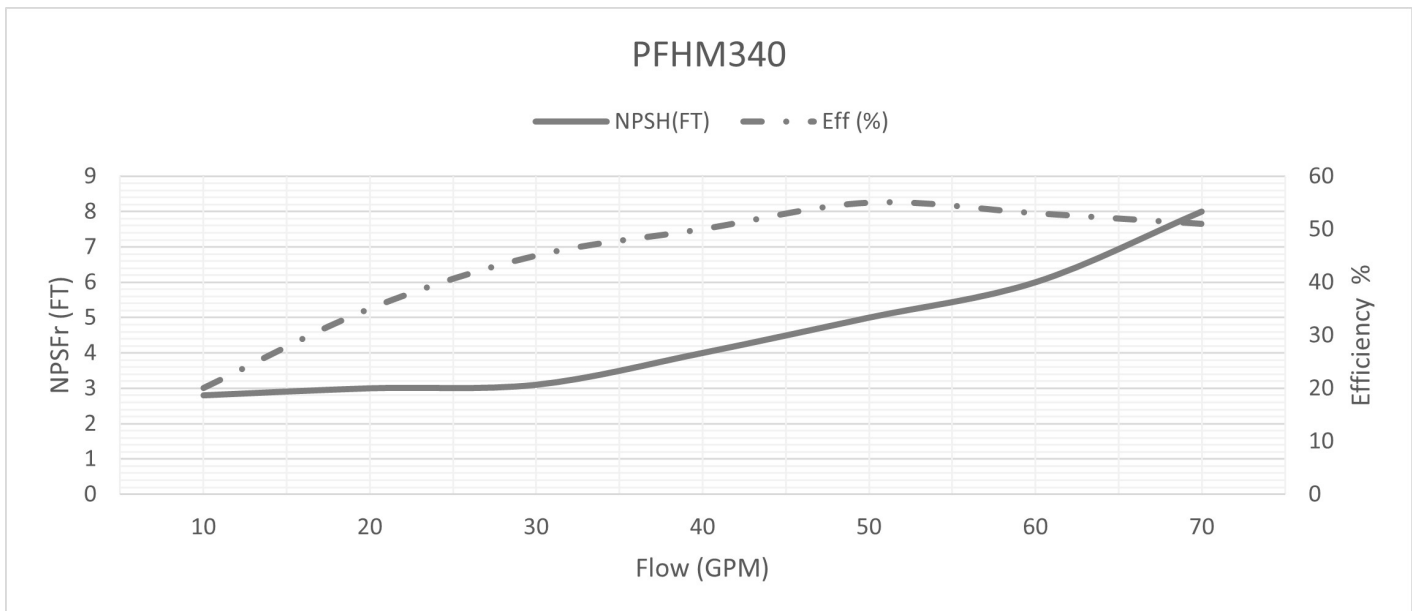
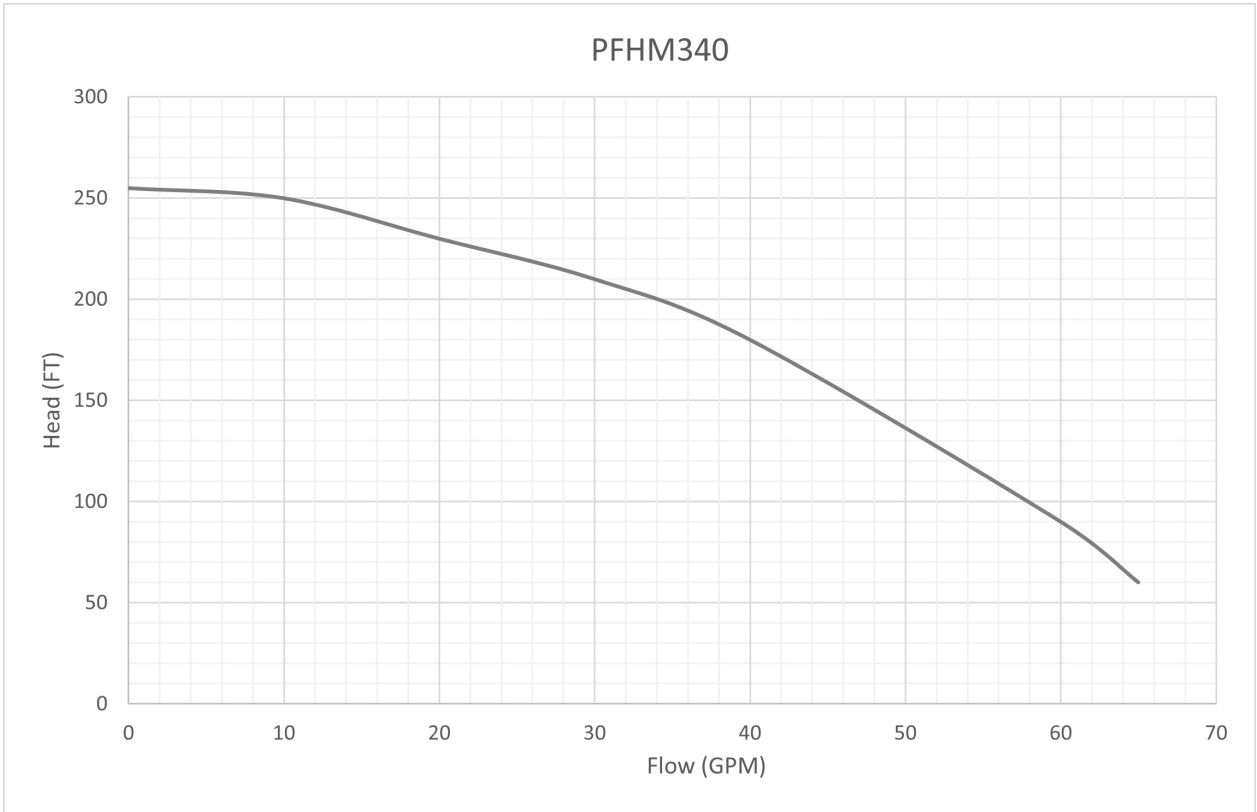

Model: PFHM613-1, PFHM330-1,
PFHM330-3, PFHM340-3

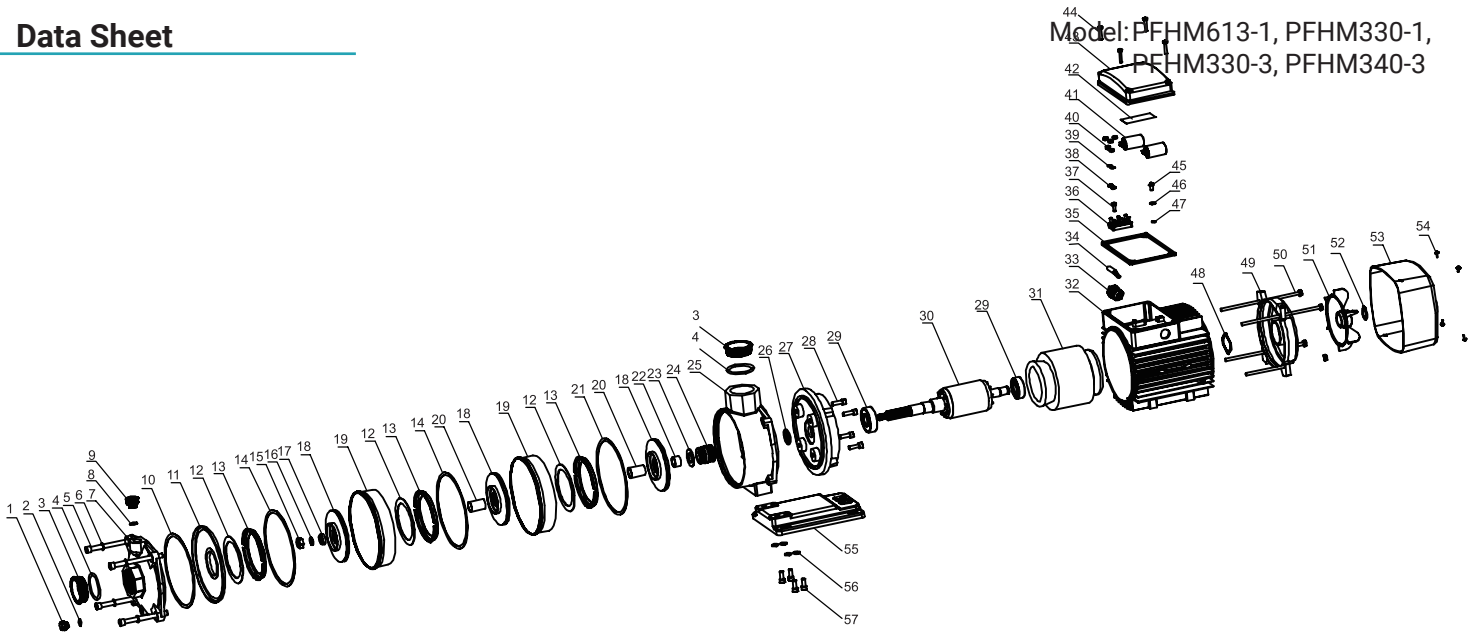

ITEM	PART NO	DESCRIPTION	CANTIDAD
1	CM8-30-1	DRAIN PLUG	1
2	CM8-30-2	O-RING ø9,2x2,4	1
3	CM8-30-3	PLASTIC LID 1-1/2"	2
4	CM8-30-4	O-RING ø46x3,5	2
5	CM8-30-5	SCREW SOCKET M8x130 G5 ZINC	4
6	CM8-30-6	PRESSURE WASER ø8	4
7	CM8-30-7	ENTRANCE SECTION	1
8	CM8-30-8	O-RING ø15x2,4	1
9	CM8-30-9	PRIMING CAP G3/8	1
10	CM8-30-10	FLAT PACKING INLET LID ø143	1
11	CM8-30-11	VOLUTE INLET COVER	1
12	CM8-30-12	TEFLON PACKAGING OUTER RING	3
13	CM8-30-13	OUTER RING FOR IMPELLER	3
14	CM8-30-14	FLAT PACKAGING ø147	2
15	CM8-30-15	NUT M10	1
16	CM8-30-16	PRESSURE WASER ø10	1
17	CM8-30-17	IMPELLER FIXING RING	2
18	CM8-30-18	IMPELLER CM8-30	3
19	CM8-30-19	VOLUTE	2
20	CM8-30-20	SHIRT L=28,5	1
21	CM8-30-21	FLAT PACKAGING ø145	1
22	CM8-30-22	SHIRT CUTS L=9.5	1
23	CM8-30-23	SPACER Ø30x17,5x1,5	1
24	CM8-30-24	MECHANICAL SEAL	1
25	CM8-30-25	OUTPUT SECTION	1
26	CM8-30-26	DEFLECTOR	1
27	CM8-30-27	MOTOR-PUMP COUPLING	1
28	CM8-30-28	SCREW HEX M6x18 G5 ZINC	4
29	CM8-30-29	BALL BEARING 6205	2

ITEM	PART NO	DESCRIPTION	CANTIDAD
30	CM8-30-30	ROTOR	1
31	CM8-30-31	STATOR	1
32	CM8-30-32	MOTOR HOUSING	2
33	CM8-30-33	CABLE OUTLET FITTING	2
34	CM8-30-34	CABLE	4
35	CM8-30-35	TERMINAL PACKAGING	4
36	CM8-30-36	CONNECTION TERMINAL	1
37	CM8-30-37	PHILLIPS SCREW M4x10	1
38	CM8-30-38	WASHER BITE ø4	1
39	CM8-30-39	FLAT WASER Ø4 ZINC	1
40	CM8-30-40	NUT HEX M4 ZINCADA	1
41	CM8-30-41	CAPACITOR 25uF/450V	3
42	CM8-30-42	CONNECTION DIAGRAM	3
43	CM8-30-43	MANHOLE COVER	2
44	CM8-30-44	PHILLIPS SCREW M4x25	1
45	CM8-30-45	PHILLIPS SCREW M5x10	1
46	CM8-30-46	PRESSURE WASHER ø5	2
47	CM8-30-47	FLAT WASHER Ø5 ZINC	3
48	CM8-30-48	WAVE WASHER	2
49	CM8-30-49	REAR ENGINE SHIELD	1
50	CM8-30-50	HEX BOLT M5x180	1
51	CM8-30-51	FAN	1
52	CM8-30-52	FAN FIXING RING	1
53	CM8-30-53	FAN COVER	1
54	CM8-30-54	PHILLIPS SCREW WITH WASHER M4x8	1
55	CM8-30-55	BASE	1
56	CM8-30-56	PRESSURE WASER Ø6 ZINC-PLATED	1
57	CM8-30-57	SCREW HEX. M6x16 GALVA-NIZED	4



1- INTRODUCTION

Read instructions carefully before installing your equipment. Save it for later reference.

Pumps have been built according to international manufacturers' standards and tested in the factory by means of hydrostatic and performance tests that guarantee their proper operation. Inspect them carefully and make sure they have no missing parts and have not deteriorated during their transportation. If a claim is necessary, send it as soon as possible to the transportation provider.



WARNING!

Power-Flo Pumps is not responsible for damages or accidents that occur due to failure to comply with the instructions provided in this manual. The warranty is only valid when using original spare parts.

2. SAFETY RECOMMENDATIONS

- Wear safety shoes when handling heavy parts or tools.
- Do not operate pumps with discharge valves closed.
- Do not remove plugs or drain valves when equipment is working.
- Never try to attach piping to the pumps by forcing it. Sizes must be suitable.
- Make sure the pump is isolated from a pressurized system before disassembling it.
- Wear safety gloves to handle parts with sharp edges or edges. Secure the pump before operating to prevent it from falling or slipping.
- Operating the pump with the discharge valve closed can cause damage to its internal parts.
- Multistage pumps are recommended only to pump clean water, without abrasive particles.
- Disconnect the pump from the power source before performing any maintenance.

These pumps are designed to operate safely when used and maintained in accordance with this manual.

A pump is a device that contains rotating parts and can therefore be dangerous. Operators and maintenance personnel should be aware of this and should follow safety recommendations.

Pumps are heavy equipment: handle them carefully.

3. ADDITIONAL RECOMMENDATIONS

Pre-installation precautions

- Be careful to avoid damaging engine terminals when unpacking the unit.
- Check the nameplate and make sure the data corresponds to the pump you purchased.
- Make sure the voltages are as specified so the pump works properly.
- Please keep this manual for later reference.

Installation Localization tips:

Location suggestions

- Place the pump at the assigned job site and make sure it is well leveled and vibration-free.
- It must be located in an accessible place and where there is adequate lighting for maintenance work.
- Elevation of the pump regarding water to be pumped, must be minimal (check against the pump NPSH at its point of best efficiency), and in no case it may exceed 25 feet (7.6m) at sea level. At higher elevations the capacity of the pump decreases markedly.



ATTENTION.

To handle the equipment, adequate lifting and transport systems must be used and comply with safety regulations.



Connections in suction :

Connect the suction pipe to the suction mouth of the body. This pipe must be aligned with the pump before making the connection. Use a separate pipe holder so its weight does not fall on the pump.

There should be no air inflows even if they are minimal, since they reduce pumping efficiency, and the pump may lose priming.

If you use a hose, keep a spare set of clamps. In installations where a pipe is used, it is important to clean inside the tube with clean water before connecting it to the pump, and avoid placing elbows, as long as it is possible. The minimum recommended distance between suction and the last elbow is 8 times the diameter of the suction pipe.

The tube diameter must be as specified by the pump body thread. If the line is longer, it can be increased.

In negative suctions a foot valve should be installed at the lower end of the suction tube.

Connections for the discharge:

- Make sure the hoses and clamps are in good shape and sufficiently sealed to stop water leaks.
 - Ensure that the total discharge height is within the pump's operating specifications and as close as possible to the point of best efficiency.
- Connections in the motor terminal box must be made according to the manufacturer's specifications.
 - The motor rotates counterclockwise when you see the side of the pump, in addition they include a plate that indicates the rotation direction, these are connected from the factory to 230V.



ATTENTION.

Pipes must be supported close to the pump body so they do not transmit any vibration to the pump.



Electrical connections must be made by qualified personnel.
Before connecting engines, check that electrical parts in which we will operate are not connected to the power supply.

- Read motor instructions for pre-installation, operation, and maintenance.
- Connections to the motor terminal box must be made according to manufacturer's specifications (see motor manual).
- Verify that the rotation direction is indicated by the arrow on the pump. If there is a three-phase motor and the rotation direction is not indicated, make the correction in the connection, inverting any two terminals and check again.

CONNECTION TRIANGLE

CONNECTION STAR

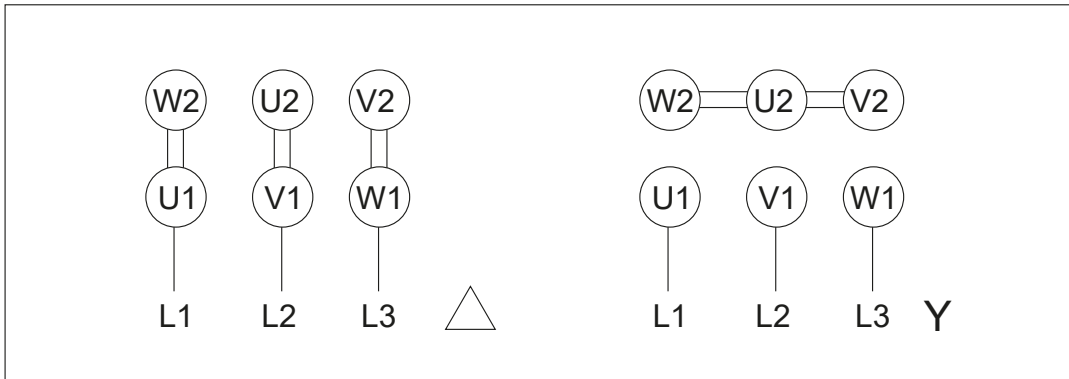



4. OPERATION

Before operating pumps, check the following:

- Voltage and other electrical data contained on the information plate.
- Motor rotation. It must be the right rotation to avoid damage to the engine and pump. Give it a gentle start and observe the rotation direction. It must match what is indicated on the plate (counterclockwise direction observed from the pump side). For three-phase pumps, if the rotation is not indicated, exchange two phases in the control board connection. Do not make changes to the motor connections. Check again.
- Hose connections.
- Fill the pump with water before running (priming)
- If the pump has not been used for long periods, check priming water before operating it again. Re-prime if necessary.
- If the pump has water with solid bodies, it is convenient to empty the body by removing the drain plug, to evacuate particles.

Prime

Fill the pump and suction pipe completely with water. Ensure that all air has been expelled out, otherwise the pump will not work properly.



WARNING!

* The cord assembly should not be used to lift or move the pump, for this use only the handle that comes installed.

After completing the electrical connection and filling, start the pump, with the drive valve closed, and check the correct rotation direction (indicated on the pump body) through the protection of the coupling or the fan cover.

ATTENTION: ABSOLUTELY AVOID DRY RUNNING, EVEN FOR TESTING



If the rotation direction is incorrect for the pump, disconnect the main power and reverse the position of two wires on the control panel or starter.

Open the valve gradually. Operation should be regular and quiet. Check the current absorbed by the engine and regulate it, if necessary, check the calibration of the thermal relay.

5.-CONTROLS.

Centrifugal pumps operation is simple and safe, and does not require an exhaustive control, however, to ensure proper functionality it is important to consider both at the first moment of start-up and after a prolonged time of operation the following situations:

Operation must be quiet and vibration-free. Verify that the flow rate and operating pressure correspond to those indicated in the work fields. Check that the absorbed power does not exceed the values indicated on the engine nameplate.



ATTENTION.

NEVER OPERATE THE PUMP FOR A LONG TIME WITH THE VALVE CLOSED, IT MAY CAUSE EXCESSIVE OVERHEATING OF THE LIQUID, AND IT CAN CAUSE DAMAGE TO THE PUMP.

6.-MAINTENANCE

The pump does not require specific inspections at pre-set intervals. However, it is advisable that as a preventive measure, the following controls, or a part of them are carried out at more or less long intervals, depending on the operating conditions.

- Fluid losses.
- Operating pressure.
- Thermal protection actuation.
- Nº of time starts.
- Noisy operation.

In case of anomalies, refer to the section on possible causes and corrective actions. The pump doesn't need any regularly scheduled routine maintenance.

It may require extraordinary maintenance that, in general, consists of cleaning hydraulic parts or replacing the mechanical seal or other worn parts.

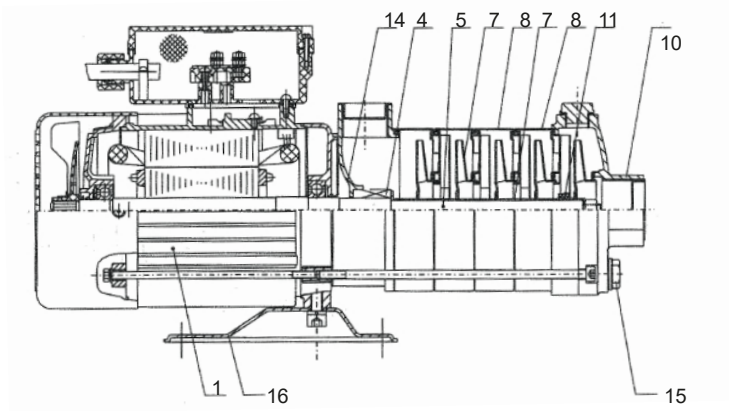

Material

No.	Description	Material	EN/DIN	AISI/ASTM
1	Motor			
2	Connector shaft			
3	Pump Head	Cast iron	EN-JL1030	ASTM25B
4	Mechanical Seal			
5	Axis	S.S	1.4507	AISI431
6	Outlet	S.S	1.4301	AISI304
7	Impeller	S.S	1.4301	AISI304
8	Volute	S.S	1.4301	AISI304
9	Support volutes	S.S	1.4301	AISI304
10	Pump body	Cast iron	EN-JL1030	ASTM25B
11	Ring	PTFE		
12	Outer insulation	S.S	1.4301	AISI304
13	O-ring	EPDM/FKM		
14	Pump Head	Iron	EN-JL1030	ASTM25B
15	Plug	S.S	1.4301	AISI304
16	Base	Steel		

7.- MALFUNCTIONS

FAILURE TYPE	PROBABLE CAUSE	SOLUTION
1.-The pump does not start	There is no power in the connections to the engine.	Review and correct
2- The pump does not discharge water, or does not discharge enough	Corroded or covered impeller. Absence of water in the pump body. (It is not primed) Very low engine speed. The suction pipe is clogged. Very high discharge height.	Clean the impeller or replace it if it is too worn or damaged. Remove the pump body and remove obstructions. Fill the pump body with water to restore priming. Adjust the engine speed control (see engine manual). Remove the suction pipe by cleaning it to remove the blockages. Check pump characteristics.
	Very high suction height. Some air access into the suction pipe. The impeller is totally or partially obstructed by some foreign material. The impeller is damaged. End of the suction pipe insufficiently submerged in water. Opposite direction of rotation	Bring the pump as close as possible to the water level. Check all connections or replace with a new pipe or reinforced hose. Use Teflon tape to tightly seal all threads. Empty the pump and put on a new impeller. Make sure the pipe is completely submerged in water, without any air being sucked by the suction line by adjusting and tightening them. Check rotation
3.-The pump starts but then the overload relay is triggered	Failure in a feeding phase. Phase imbalance. Poor regulation or defective relay. Rotor locked. The supply voltage does not correspond to the one the engine needs.	Control the phases balance. Control the setting. Replace the overload relay Send to specialized technical service Replace the engine or control power.



8. WARRANTY

Power-Flo Pumps guarantees the Multi-Stage Pumps for a period of 12 months from the date of delivery, for any defect in materials and manufacturing, according with what is indicated in its general conditions for sale.

Failure to comply with the suggestions and recommendations of this manual, as well as the incorrect use or unauthorized handling of the product, totally avoids warranty.

The warranty excludes wear and tear, misuse, repair, or replacement of the defective part by the user or unqualified personnel without the express authorization of Power-Flo Pumps.



ATTENTION !

Any anomaly detected must be reported immediately to Power-Flo Pumps.



Not sure about which pump to choose or where to start? Simply scan our QR code to unlock our comprehensive manual, designed to guide you through the process of finding the perfect pump for your specific needs. Contact Power-Flo Pumps today.

