

**Models: PFG3022, PFG3032, PFG3042
PFG5022, PFG5032, PFG5042
PFG7532, PFG7542**

Features:

Designed to reduce domestic, commercial, institutional and light industrial sewage to a finely ground slurry.

- **DISCHARGE:** 2" NPT Vertical
- **LIQUID TEMPERATURE:** 160°F Intermittent
- **MOTOR HOUSING, VOLUTE & SEAL PLATE:** Cast Iron, Class 30
- **IMPELLER:** 12 vane, Vortex with pump out vanes on back side, Dynamically balanced, ISO G6.3, Cast iron
- **SHREDDING RING & CUTTER:** Stainless steel
- **SHAFT & HARDWARE:** Stainless steel
- **PAINT:** Air dry enamel
- **SQUARE RINGS:** Buna-N
- **SEAL:** Tandem Double Mechanical, Oil Filled Reservoir, Upper - 1.25 inch, Carbon/Ceramic/Buna-N, Lower - 1.125 inch, Silicon Carbide/Silicon Carbide/Viton Stainless Hardware
- **UPPER BEARING:** Single row, ball, oil lubricated
- **LOWER BEARING:** Single row, ball, oil lubricated
- **POWER CORD:** 30 Ft. SOW, 10/4 Cord, Pressure Grommet for Sealing and Strain Relief
- **CONTROL CORD:** 30 Ft., SOW, 18/5, 0.47" OD., Cord. Pressure Grommet for Sealing and Strain Relief
- **MOTOR:** Class F Insulation, Oil Filled, Squirrel cage induction
- **SINGLE PHASE:** Capacitor Start/Capacitor Run, Requires overload protection in the control panel, Requires starter or control panel which includes capacitors
- **THREE PHASE:** Dual Voltage 230/460. Requires overload protection in control panel
- **SEAL LEAK SENSOR:** Two probe design, Normally Open (NO). Requires relay in control panel, (Included in listed panels)
- **TEMPERATURE SENSOR:** Normally Closed (NC). Requires relay in control panel, (Included in listed panels)
- **WARRANTY:** 1 year



WARNING: CANCER AND REPRODUCTIVE HARM-
WWW.P65WARNINGS.CA.GOV



**Submersible Grinder
PFG
2" Discharge,
Double Seal**

MODEL	HP	Hz	Volts/ Ph	RPM	Full Load Amps	Locked Rotor Amps	NEMA Start Code	Cord Type	Cord Size	Cord O.D.	Simplex Panel	Duplex Panel
PFG3022	3	60	230/1	3450	26	90	H	SOW	10/4	.75	PF1053-COST-40	PF2053-COST-40
PFG3032	3	60	230/3	3450	14.5	62	K	SOW	10/4	.75	PF1034-OST-20	PF2034-OST-20
PFG3042	3	60	460/3	3450	7.2	31	K	SOW	10/4	.75	PF1035-OST	PF2035-OST
PFG5022	5	60	230/1	3450	39	136	H	SOW	10/4	.75	PF1053-COST-40	PF2053-COST-40
PFG5032	5	60	230/3	3450	21.9	120	L	SOW	10/4	.75	PF1054-OST-25	PF2054-OST-25
PFG5042	5	60	460/3	3450	11	60	L	SOW	10/4	.75	PF1055-OST	PF2055-OST
PFG7532	7.5	60	230/3	3450	22.3	136	J	SOW	10/4	.75	PF1084-OST-25	PF2084-OST-25
PFG7542	7.5	60	460/3	3450	11.2	68	J	SOW	10/4	.75	PF1085-OST-20	PF2085-OST-20

IMPORTANT! - DO NOT introduced into any sewer, either directly, or through a kitchen waste disposal unit or toilet: *Seafood Shells, Aquarium Gravel, Cat Litter, Plastic Objects (toys, utensils, etc.), Sanitary Napkins or Tampons, Diapers, Rags, Disposable Wipes or Cloth, Medications, Flammable Material, Oil or Grease, Strong Chemicals, or Gasoline.*

These pumps are not approved for use in swimming pools, recreational water parks, or installations where human contact with pumped media is a common occurrence.

Single phase models require **Capacitor/Relay Pack PF73305**, available for panels by others.
Seal Leak Sensor Relay kit PF0861 & **Temperature Sensor Relay Kit PF0876** are available for panels by others.
Optional **Pump Stand PF82306** or **Leg Kit PF92010003B** available.



Power-Flo Pumps & Systems

a Power-Flo Technologies company

877-24PUMPS • fax: 516-812-6897 • www.powerflopumps.com

2" - Grinder Pumps - PFG - 3, 5, 7.5HP - 3450RPM - 60Hz

2" - Grinder Pumps - PFG - 3, 5, 7.5HP - 3450RPM - 60Hz

**Models: PFG3022, PFG3032, PFG3042
PFG5022, PFG5032, PFG5042
PFG7532, PFG7542**

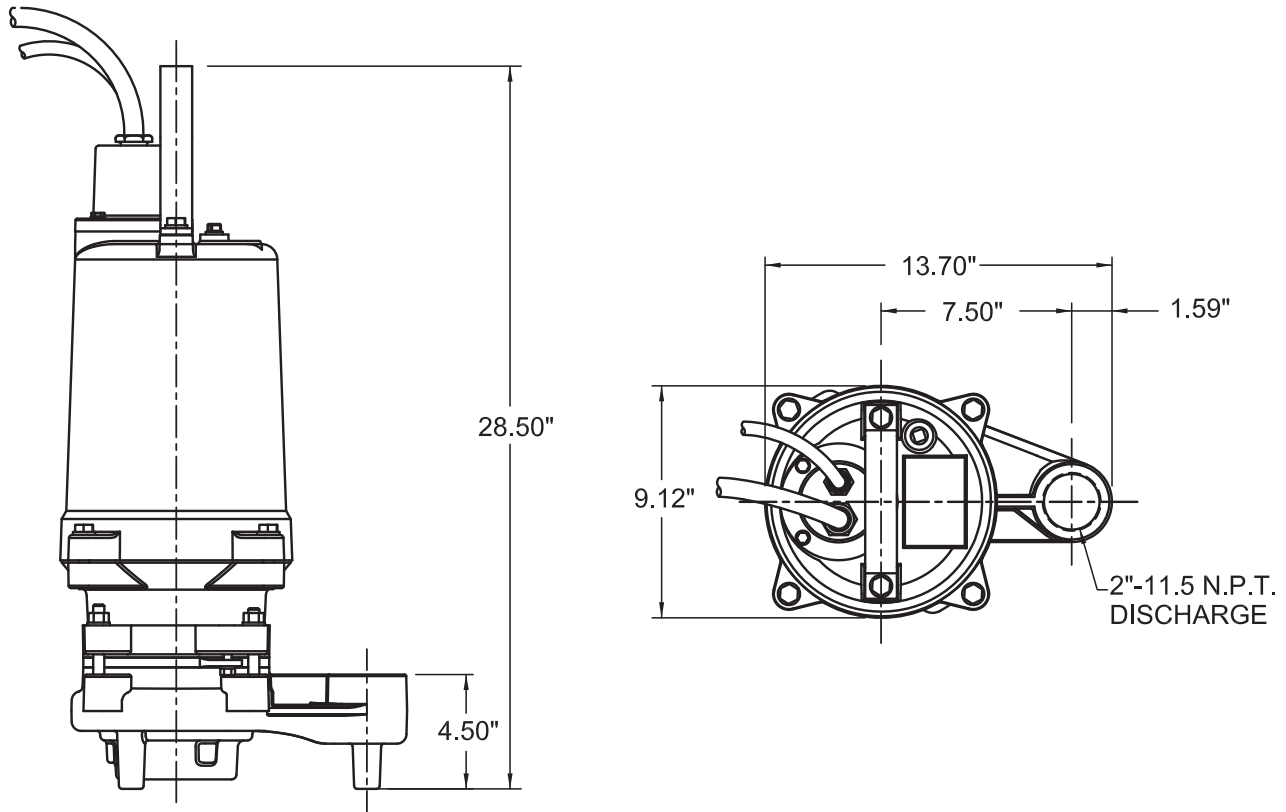

IMPORTANT! - Pump Suction **MUST** be a minimum of 3" from basin floor with use of stand or slide rail system.

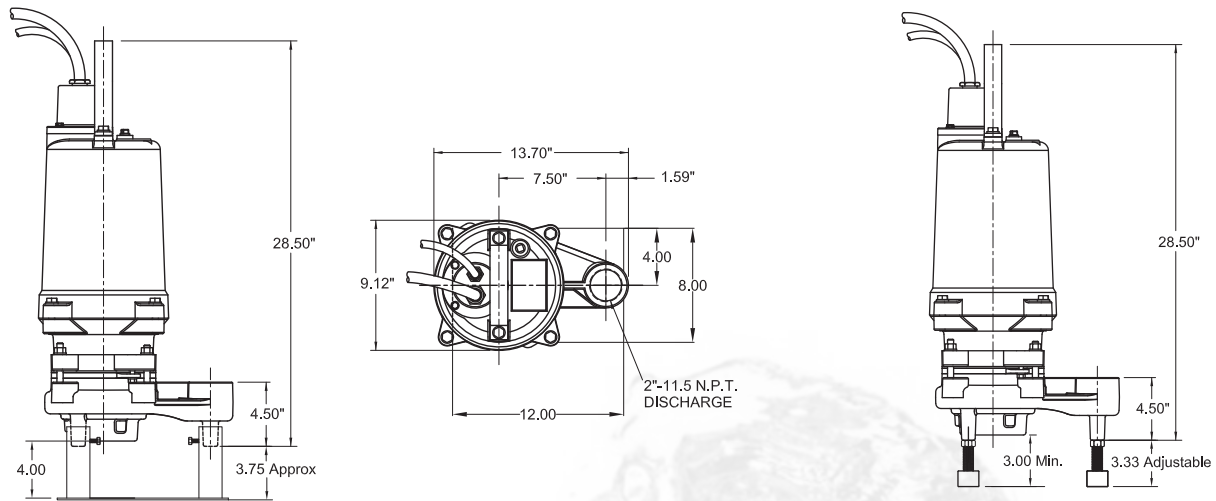

Shown with Optional Grinder Pump Stand P/N: PF82306

**Shown with Optional
Grinder Pump Leg Kit P/N:
PF92010003B**



**Models: PFG3022, PFG3032, PFG3042
PFG5022, PFG5032, PFG5042
PFG7532, PFG7542**

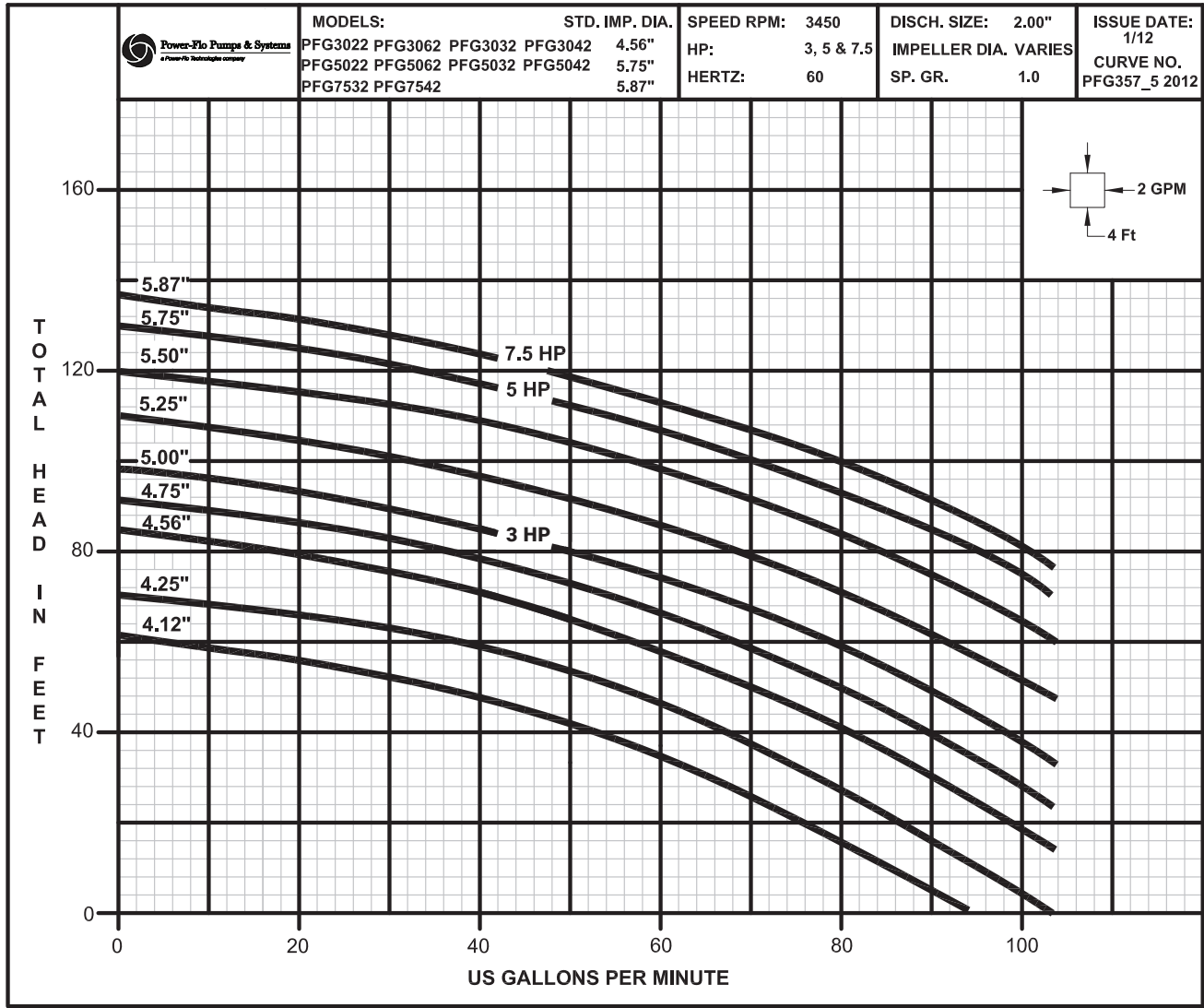

2" - Grinder Pumps - PFG - 3, 5, 7.5HP - 3450RPM - 60Hz



Power-Flo Pumps & Systems
a Power-Flo Technologies company

877-24PUMPS • fax: 516-812-6897 • www.powerflopumps.com

Sect. G
Page 15
Rev. 02/2021