

Models: PFG3022, PFG5022

Submersible Grinder Pumps are designed to reduce domestic, commercial, institutional and light industrial sewage to a finely ground slurry.

- **DISCHARGE:** 2" NPT, Female, Vertical
- **LIQUID TEMPERATURE:** 160°F Intermittent
- **MOTOR HOUSING, VOLUTE, & SEAL PLATE:** Cast Iron, Class 30
- **IMPELLER:** 12 vane, Vortex with pump out vanes on back side, Dynamically balanced, ISO G6.3, Cast iron
- **SHREDDING RING & CUTTER:** Stainless steel
- **SHAFT & HARDWARE:** Stainless steel
- **PAINT:** Air dry enamel
- **SQUARE RINGS:** Buna-N
- **SEAL:** Tandem Double Mechanical, Oil Filled Reservoir
Upper - 1.25 inch, Carbon/Ceramic/Buna-N
Lower - 1.125 inch, Silicon Carbide/Silicon Carbide/Viton
Stainless Hardware
- **UPPER BEARING:** Single row, bail, oil lubricated
- **LOWER BEARING:** Single row, bail, oil lubricated
- **POWER CORD:** 30 Ft. SOW, 10/4 Cord, Pressure Grommet for Sealing and Strain Relief
- **CONTROL CORD:** 30 Ft. SOW, 18/5 Cord. Pressure Grommet for Sealing and Strain Relief
- **MOTOR:** Class F Insulation, Oil Filled, Squirrel cage induction
- **SINGLE PHASE:** Capacitor Start/Capacitor Run,
Requires overload protection in the control panel,
Requires starter or control panel which includes capacitors
- **SEAL LEAK SENSOR:** Two probe design, Normally Open (NO).
Requires relay in control panel, (Included in listed panels)
- **TEMPERATURE SENSOR:** Normally Closed (NC). Requires relay in control panel, (Included in listed panels)
- **WARRANTY:** 1 year



**Submersible Grinder
PFG
2" Discharge,
Double Seal**



**WARNING: CANCER AND
REPRODUCTIVE HARM-**
WWW.P65WARNINGS.CA.GOV

Not sure about which pump to choose or where to start? Simply scan our QR code to unlock our comprehensive manual, designed to guide you through the process of finding the perfect pump for your specific needs. Contact Power-Flo Pumps today.



MODEL	HP	Hz	Volts/ Ph	RPM	Full Load Amps	Locked Rotor Amps	NEMA Start Code	Cord Type	Cord Size	Cord O.D.	Simplex Panel	Duplex Panel
PFG3022	3	60	230/1	3450	26	90	H	SOW	10/4	.75	PF1053-COST-40	PF2053-COST-40
PFG5022	5	60	230/1	3450	39	136	H	SOW	10/4	.75	PF1053-COST-40	PF2053-COST-40

IMPORTANT! - *DO NOT* introduced into any sewer, either directly, or through a kitchen waste disposal unit or toilet: ***Seafood Shells, Aquarium Gravel, Cat Litter, Plastic Objects (toys, utensils, etc.), Sanitary Napkins or Tampons, Diapers, Rags, Disposable Wipes or Cloth, Medications, Flammable Material, Oil or Grease, Strong Chemicals, or Gasoline.***

These pumps are not approved for use in swimming pools, recreational water parks, or installations where human contact with pumped media is a common occurrence.

Single phase models require **Capacitor/Relay Pack PF73305**, available panels by others.

Seal Leak Sensor Relay kit PF0861 & Temperature Sensor Relay Kit PF0876 are available for panels by others.

Optional **Pump Stand PF82306** or **Leg Kit PF92010003B** available.



2" Grinder Pumps - PFG 3,5 HP - 3450RPM - 60Hz

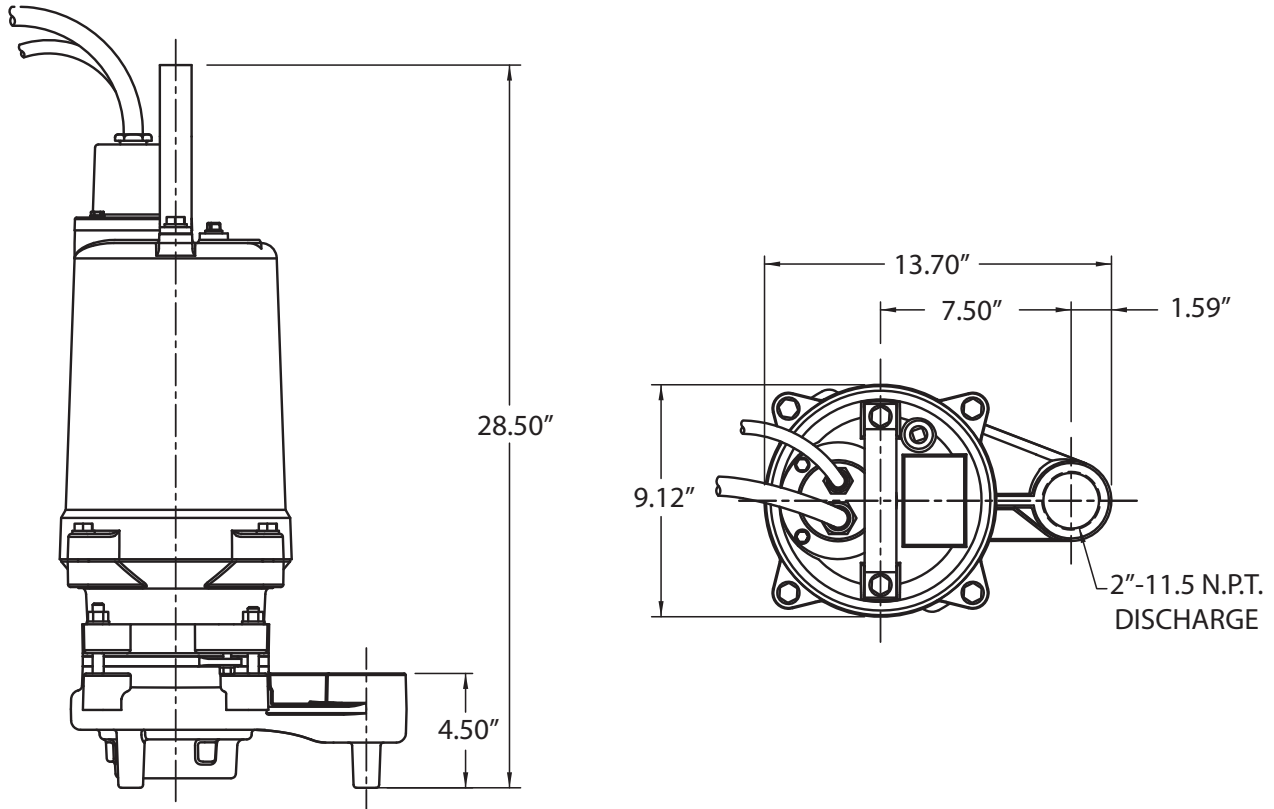

IMPORTANT! - Pump Suction **MUST** be a minimum of 3" from basin floor with use of stand or slide rail system.

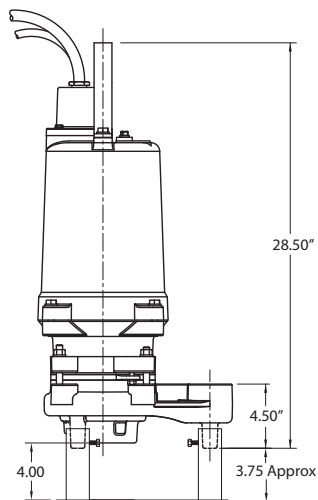

Shown with Optional Grinder Pump Stand P/N: PF82306

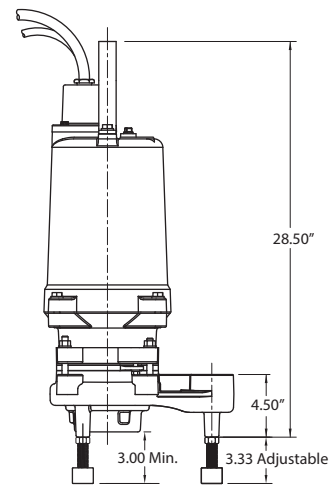
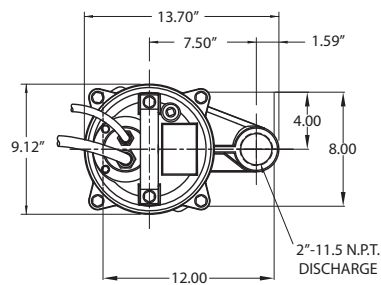

Shown with Optional Grinder Pump Leg Kit P/N: PF92010003B

